

# VARIUS SPECTROMETER



## STARLINE



Meet the Varius, a flexible spectrometer specifically designed to meet the needs of a wide variety of applications. The Varius is available with a 2k or 4k pixel detector, both of which are compatible with Avantes light sources, accessories, and AvaSoft software.

Additionally, the Varius spectrometer provides excellent price-to-performance ratio, making it a great choice for laboratories and research institutions seeking a powerful, reliable, and affordable spectroscopy solution.

## PRODUCT VARIATIONS

To provide our customers with the best possible service, the Varius spectrometer is available in two product variations.

### 1. Varius

Available with 2048 or 4096 pixel detector, USB3 high speed data transfer, and a replaceable slit to customize your throughput and resolution.

### 2. Varius OEM

Industrial OEM-version with a stainless steel electromagnetic compatible housing. Optimized for integration into your product or system.

## WHY THE VARIUS?

- Patent-pending optical bench design
- Flexible performance through replaceable slit
- Versatile spectroscopy design
- Semi-automated production for unsurpassed inter-instrument reproducibility & scalability
- Superior stray light performance
- High signal-to-noise ratio
- Easy to operate with intuitive software
- Cost-effective instrument

## APPLICATIONS & INDUSTRIES

The Varius is optimized for a wide variety of applications and industries. Including, but not limited to;



**Agriculture & Food**  
Leaf measurements  
Chlorophyll analysis

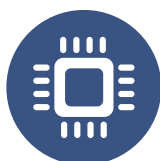

**Semiconductor**  
Thin Film Coating  
Coating Deposition



**Lighting**  
Quality Control  
Radiometry



**Laboratory**  
Research and  
Chemistry labs



**System Integration**  
Integrate into your  
product or system

# SPECIFICATIONS VARIUS

The dimensions of the Varius OEM may differ from the ones below. Scan the QR-code below for the full specifications of all variants.

	Varius 2K	Varius 4K
Optical Bench	Symmetrical Czerny-Turner design, 75 mm focal length; Pacto bench	
Wavelength range	190 - 1100 nm	
Stray light	0.1 - 1% (typical value 300 l/mm, blaze 300 nm < 0.3%)	
Detector	HAM S11639, CMOS linear array, 2048 pixels (14x200 µm)	HAM S13496, CMOS linear array, 4096 pixels (7x200 µm)
Signal/Noise	375:1	365:1
Dynamic Range	4500	
Dark noise	15 cnts	
AD converter	16-bit, 6 MHz	
Integration time	9 µs – 30 s	
Interface	USB 3.0 high speed (5Gbps), Gigabit Ethernet (1 Gbps)	
Sample speed on-board averaging	0.38 ms/scan	0.70 ms/scan
Data transfer speed	0.38 ms/scan (USB3.0), 1.0 ms (ETH)	0.70 ms/scan (USB3.0), 1.31 ms (ETH)
Digital I/O	HD-26 connector, 2 Analog in, 2 Analog out, 13 Digital bidirectional, trigger, sync., strobe, laser	
Dimensions, weight	183 x 130 x 45,2 mm, 1068 grams	
Power supply	Default USB3 power, 500 mA or 12 VDC, 300 mA	
Temperature range	5-55 °C	

## DIMENSIONS

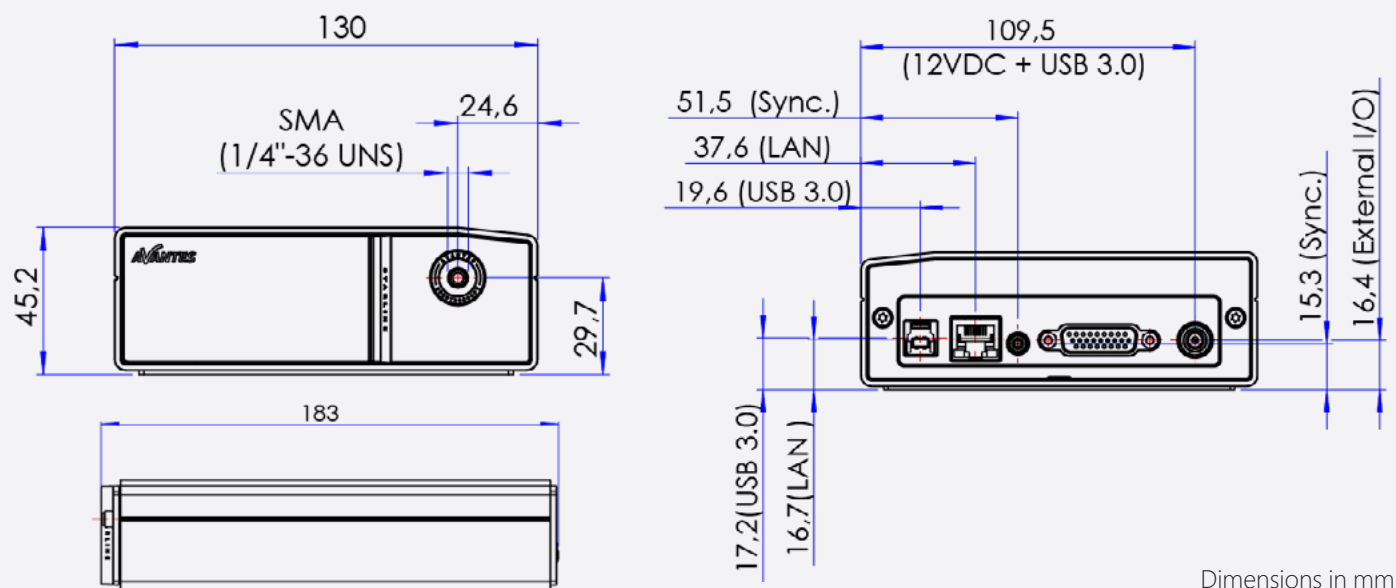

## FULL PRODUCT OVERVIEW & SPECIFICATIONS

Scan the QR-code for the full product specifications, grating options, ordering options, and more. Discover the flexibility of the Varius and find your ideal variation.

Discover all our empowering spectroscopy solutions on our website [www.avantes.com](http://www.avantes.com)

*We reserve the right to make changes without prior notice. While every effort has been made to ensure all information in this document is accurate, Avantes accepts no liability for any inaccuracies.*

**PHOTO  
TECHNICA**

[www.phototechnica.co.jp](http://www.phototechnica.co.jp)  
フォトテクニカ株式会社

〒336-0017 埼玉県さいたま市南区南浦和 1-2-17  
TEL: 048-871-0067 FAX: 048-871-0068  
e-mail: voc@phototechnica.co.jp

**AVANTES**  
MEMBER OF THE NYNOMIC GROUP

# VARIUS SPECTROMETER

## TECHNICAL DATA

### SPECIFICATIONS

	Varius 2K	Varius 4K
Optical Bench	Symmetrical Czerny-Turner design, 75 mm focal length; Compact spectrometer bench	
Wavelength range	190 - 1100 nm	
Stray light	0.1 - 1% (typical value 300l/mm, blaze 300 nm < 0.3%)	
Detector	HAM S11639, CMOS linear array, 2048 pixels (14x200 µm)	HAM S13496, CMOS linear array, 4096 pixels (7x200µm)
Signal/Noise	375:1	365:1
Dynamic Range	4500	
Dark noise	15 cnts	
AD converter	16-bit, 6 MHz	
Integration time	9 µs – 30 s	
Interface	USB3.0 high speed, 5 Gbps, Gigabit Ethernet (1 Gbps)	
Sample speed on-board averaging	0.38 ms/scan	0.70 ms/scan
Data transfer speed	0.38 ms/scan (USB3), 1.0 ms (ETH)	0.70 ms/scan (USB3), 1.31 ms (ETH)
Digital I/O	HD-26 connector, 2 Analog in, 2 Analog out, 13 Digital bidirectional, trigger, sync., strobe, laser	
Dimensions, weight	183 x 130 x 45,2 mm, 1068 grams	
Power supply	Default USB3 power, 500 mA or 12 VDC, 300 mA	
Temperature range	5-55 °C	

### GRATINGS

Use	Useable range (nm)	Spectral range (nm)	Lines/mm	Blaze (nm)	Order code
UV/VIS/NIR	190-1100**	910**	300	300	MN0300-0.30
UV/VIS	190-780	544-540*	600	300	MN0600-0.30
UV	190-532	261-256*	1200	250	MN1200-0.25
UV	190-472	168-152*	1800	UV	MN1800-0.25
UV	190-423	121-103*	2400	UV	MN2400-0.25
UV	190-337	72-57*	3600	UV	MN3600-0.25
UV/VIS	280-852	536-532*	600	400	MN0600-0.40
VIS/NIR	300-1100**	800**	300	500	MN0300-0.50
VIS	350-959	529-519*	600	500	MN0600-0.50
VIS	320-776	247-216*	1200	500	MN1200-0.50
VIS	360-641	147-121*	1800	500	MN1800-0.50
VIS	350-640	96-89*	2400	VIS	MN2400-0.50
NIR	480-1066	515-506*	600	750	MN0600-0.75
NIR	600-844	210-204*	1200	750	MN1200-0.75
NIR	600-1100	339-300*	830	800	MN0830-0.80
NIR	600-1100**	500**	300	1000	MN0300-1.00
NIR	600-1100	500	600	1000	MN0600-1.00

Note: a selection of starting wavelength is possible, contact us for available configurations.

\* Depends on the starting wavelength of the grating; the higher the wavelength, the bigger the dispersion and smaller the range to select

\*\* Please note that not all pixels will be used for the useable range

**MORE DATA ON THE NEXT PAGE >**

## RESOLUTION VARIUS 2K

Slit size (μm)	10	25	50	100	200	500
300 lines/mm grating	1.0	1.4	2.25	4.8	9.2	21.3
600 lines/mm grating	0.40-0.53*	0.7	1.2	2.4	4.6	10.8
830 lines/mm grating	0.32	0.48	0.93	1.7	3.4	8.5
1200 lines/mm grating	0.20-0.28*	0.27-0.38*	0.52-0.66*	1.1	2.3	5.4
1800 lines/mm grating	0.10-0.18*	0.20-0.29*	0.34-0.42*	0.8	1.6	3.6
2400 lines/mm grating	0.09-0.13*	0.13-0.17*	0.26-0.34*	0.44-0.64*	1.1	2.7
3600 lines/mm grating	0.06-0.08*	0.10	0.19	0.4	0.8	1.8

\*Depends on the starting wavelength of the grating; the higher the wavelength, the bigger the dispersion and the higher the resolution.

## RESOLUTION VARIUS 4K

Slit size (μm)	10	25	50	100	200	500
300 lines/mm grating	0.50-0.70	1.4	2.25	4.8	9.2	21.3
600 lines/mm grating	0.30-0.36*	0.7	1.2	2.4	4.6	10.8
830 lines/mm grating	0.25	0.48	0.93	1.7	3.4	8.5
1200 lines/mm grating	0.14-0.18*	0.27-0.38*	0.52-0.66*	1.1	2.3	5.4
1800 lines/mm grating	0.09-0.11*	0.20-0.29*	0.34-0.42*	0.8	1.6	3.6
2400 lines/mm grating	0.07-0.09*	0.13-0.17*	0.26-0.34*	0.44-0.64*	1.1	2.7
3600 lines/mm grating	0.05-0.06*	0.10	0.19	0.4	0.8	1.8

\*Depends on the starting wavelength of the grating; the higher the wavelength, the bigger the dispersion and the higher the resolution.

## PRODUCT AVAILABILITY

The Varius spectrometer will be available for purchase in Q4, 2023. Fill out your email address on the [Varius product page](#) and be the first to receive updates regarding purchase availability.



[www.phototechnica.co.jp](http://www.phototechnica.co.jp)

フォトテクニカ株式会社

〒336-0017 埼玉県さいたま市南区南浦和 1-2-17  
TEL: 048-871-0067 FAX: 048-871-0068  
e-mail: voc@phototechnica.co.jp